

GRUPPOLUBE



ACCESSORI ORGANIZER

2023



PORTACOPERCHI LID HOLDER

- Barra in acciaio da montare in un cassetto, studiata appositamente per lo stoccaggio dei coperchi.
Steel bar to be mounted in a drawer, specially designed for lid storage.
- Fissaggio semplice con viti (non in dotazione).
Simple fixing with screws (not supplied)
- Larghezza 51/79 mm
Width 51/79 mm

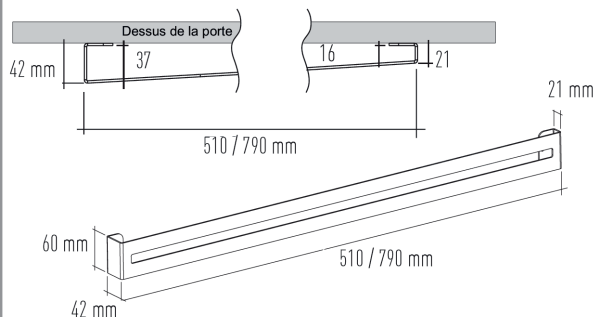

N.B.: NON DISPONIBILE PER ANTE TELAIO E ANTE VETRO
Note: not available for frame doors and glass doors

CODICE code

grigio orione orion gray L51	08704000G
bianco white L51	08704000B
nero opaco matt black L51	08704000N
grigio orione orion gray L79	08704001G
bianco white L79	08704001B
nero opaco matt black L79	08704001N



PORTACOPERCHI "ELASTICO" LID HOLDER "ELASTIC"

- Barra in acciaio da montare in un cassetto, la posizione dell'elastico è modulabile.
Steel bar to be mounted in a drawer, the position of the elastic is modular.
- L'elastico consente di stoccare utensili.
The elastic band allows you to store tools.
- Viti di fissaggio ed elastico di ricambio in dotazione.
Fixing screws and spare elastic included.
- Larghezza 51/79 mm
Width 51/79 mm

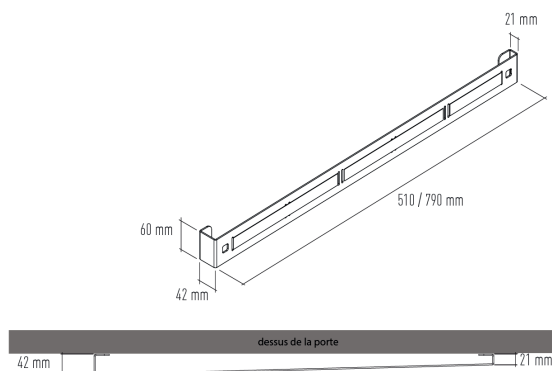

N.B.: NON DISPONIBILE PER ANTE TELAIO E ANTE VETRO
Note: not available for frame doors and glass doors

CODICE code

nero opaco matt black L51	08704005N
nero opaco matt black 79	08704006N



ORGANIZZATORE SOTTOLAVELLO "MULTY" "MULTY" UNDER-SINK ORGANIZER

- Consente lo stoccaggio dei sacchetti della spazzatura, degli spray e di vari articoli per la casa.
Allows for the storage of trash bags, sprays and various household items.
- Con fermi per sostenere gli spray.
With stops to hold the sprays.
- Da montare a destra o a sinistra del sifone.
To be mounted to the right or left of the siphon.
- In metallo verniciato, viteria in dotazione.
In painted metal, screws supplied.

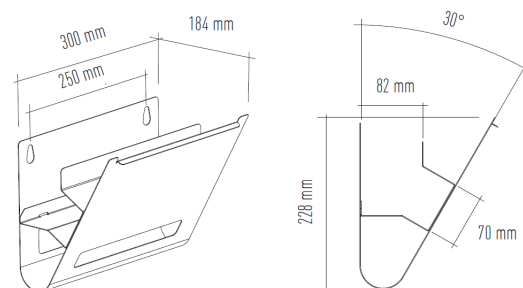

CODICE
code

grigio orione orion gray 08704040G

nero opaco matt black 08704040N

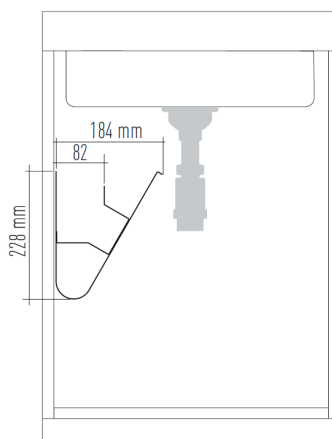

Mobile sottolavello
vista frontale

under-sink cabinet
front view

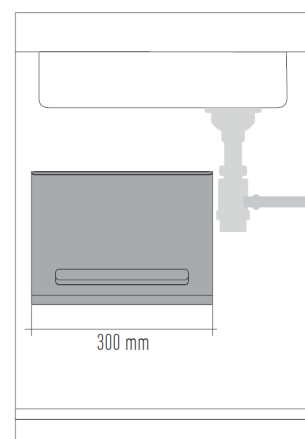

Mobile sottolavello
vista di profilo

under-sink cabinet
profile view



ORGANIZZATORE SOTTOLAVELLO "BIRD" "BIRD" UNDER-SINK ORGANIZER

- Consente lo stoccare bottiglie lasciando vuota la parte inferiore del mobile.
Allows you to store bottles leaving the lower part of the cabinet empty.
- Capacità massima 8 bottiglie/8 Kg.
Maximum capacity 8 bottles / 8 Kg.
- Da montare a destra o a sinistra del sifone.
To be mounted to the right or left of the siphon.
- In metallo verniciato.
In painted metal.
- Fissaggio sul fianco del mobile, viteria in dotazione.
Fixing on the side of the cabinet, screws supplied.

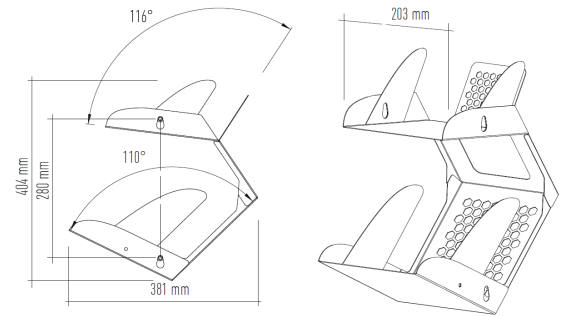

CODICE
code

grigio orione orion gray 08704041G

nero opaco matt black 08704041N

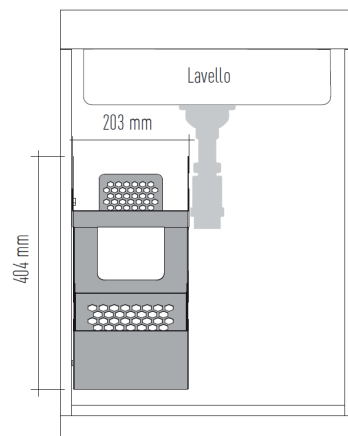

**Mobile sottolavello
vista frontale**

under-sink cabinet
front view

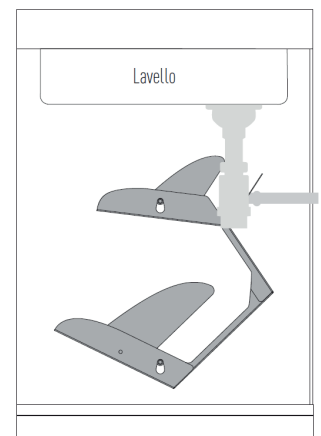

**Mobile sottolavello
vista di profilo**

under-sink cabinet
profile view



PORTABICCHIERI SINGOLO SINGLE WINE GLASS HOLDER

- Capacità 3 bicchieri.
Capacity 3 glasses.
- Fissaggio sotto pensile o mensola.
Fixing under wall unit or shelf.
- Viti non in dotazione.
Screws not supplied.

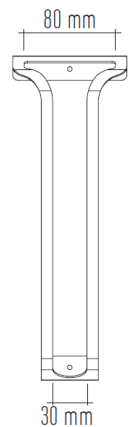
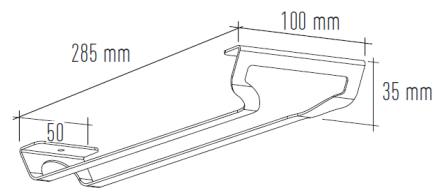

CODICE code

acciaio satinato	08704010X
satin steel	
bianco opaco matt white	08704010B
nero opaco matt black	08704010N
oro opaco matt gold	08704010K
rame opaco matt copper	08704010R



PORTABICCHIERI TRIPLO TRIPLE WINE GLASS HOLDER

- Capacità 9 bicchieri.
Capacity 9 glasses.
- Fissaggio sotto pensile o mensola.
Fixing under wall unit or shelf.
- Viti non in dotazione.
Screws not supplied.

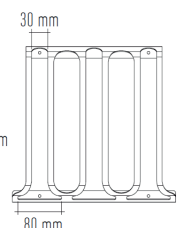
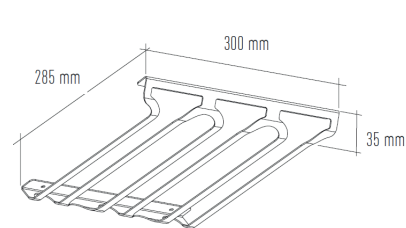

CODICE code

acciaio satinato	08704013X
satin steel	
bianco opaco matt white	08704013B
nero opaco matt black	08704013N
oro opaco matt gold	08704013K
rame opaco matt copper	08704013R



PORTABICCHIERI PROFONDITÀ RIDOTTA

WINE GLASS HOLDER WITH REDUCED DEPTH

- Capacità 6 bicchieri (lunghezza 600 mm).
- Capacità 9 bicchieri (lunghezza 900 mm).
- Capacity 6 glasses (length 600 mm).
- Capacity 9 glasses (length 900 mm).
- Fissaggio sotto pensile o ripiano.
- Fixing under wall unit or shelf.
- Viti non in dotazione.
- Screws not supplied.

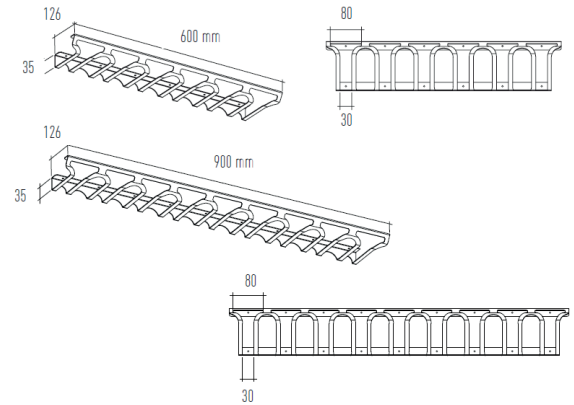

CODICE
code

nero opaco lunghezza 600 mm
matt black length 600 mm 08704023N

nero opaco lunghezza 900 mm
matt black length 900 mm 08704025N



PORTATAZZE

CUP HOLDER

- In acciaio finitura nero opaco.
- In matt black finish steel.
- Fissaggio sotto o dentro il pensile con 2 viti (non in dotazione).
- Fixing under or inside the wall unit with 2 screws (not supplied).
- Capacità 4 tazze.
- Capacity 4 cups.

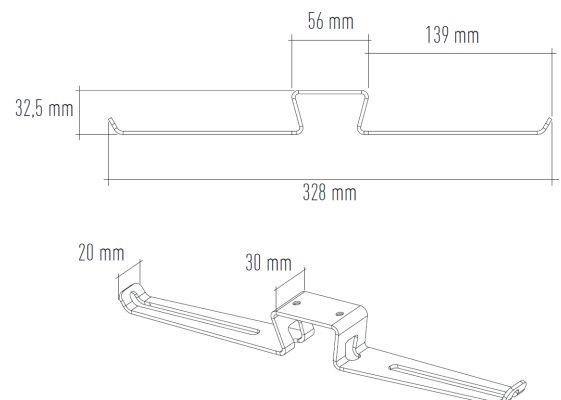

CODICE
code

nero black

08704015N



FORMA STELLA
STAR SHAPE



SPECIALE PIATTO LUNGO
SPECIAL LONG PLATE

SOTTOPENTOLA ACCIAIO INOX
STAINLESS STEEL TRIVET

- Per poggiare pentole, padelle e piatti caldi appena terminata la cottura.

To place pots, pans and hot plates after cooking.

- In acciaio inossidabile.

In stainless steel.

- Pronto all'installazione sul top grazie al biadesivo termoresistente premontato sotto ogni barretta, non è necessario forare il top.

Ready to install on the worktop thanks to the heatresistant double-sided adhesive pre-assembled under each bar, it is not necessary to drill the worktop.

- Per tutti i tipi di top purchè la superficie sia liscia..

For all types of worktops as long as the surface is smooth.

FORMA STELLA

costituito da 8 barrette da 80 mm.

STAR SHAPE

consisting of 8 bars of 80 mm

SPECIALE PIATTO LUNGO

costituito da 8 barrette da 130 mm.

SPECIAL LONG PLATE

consisting of 8 bars of 130 mm

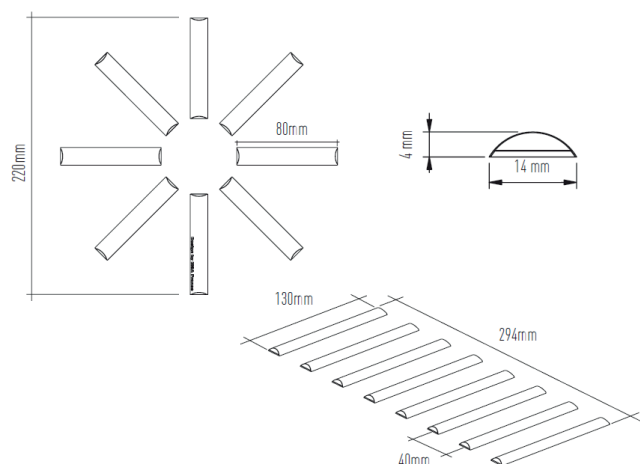

CODICE
code

acciaio satinato
forma stella
satin steel star shape

08704030X

acciaio satinato
specialepiatto lungo
satin steel special long plate

08704031X



SOTTOPENTOLA ACCIAIO INOX STAINLESS STEEL TRIVET

- Per poggiare pentole, padelle e piatti caldi appena terminata la cottura.
To place pots, pans and hot plates after cooking.
- In acciaio inossidabile.
In stainless steel.
- Pronto all'installazione sul top grazie al biadesivo termoresistente premontato sotto ogni barretta, non è necessario forare il top.
Ready to install on the worktop thanks to the heatresistant double-sided adhesive pre-assembled under each bar, it is not necessary to drill the worktop.
- Per tutti i tipi di top purchè la superficie sia liscia.
For all types of worktops as long as the surface is smooth.
- Costituito da 6 barrette da 296 mm.
Made up of 6 bars of 296 mm.

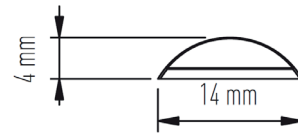

CODICE
code

acciaio inox
stainless-steel
nero black

08704032X
08704032N



SOTTOPENTOLA ACCIAIO INOX STAINLESS STEEL TRIVET

- Per poggiare pentole, padelle e piatti caldi appena terminata la cottura.
To place pots, pans and hot plates after cooking.
- In acciaio inossidabile.
In stainless steel.
- Pronto all'installazione sul top grazie al biadesivo termoresistente premontato sotto ogni barretta, non è necessario forare il top.
Ready to install on the worktop thanks to the heatresistant double-sided adhesive pre-assembled under each bar, it is not necessary to drill the worktop.
- Per tutti i tipi di top purchè la superficie sia liscia.
For all types of worktops as long as the surface is smooth.
- Costituito da 2 barrette da 296 mm,
2 da 250 mm e 2 da 130 mm.
Made up of 2 bars of 296 mm,
2 of 250 mm and 2 of 130 mm.

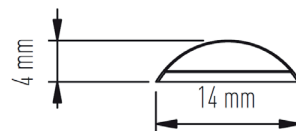

CODICE
code

acciaio inox
stainless-steel
nero black

08704033X
08704033N



SOTTOPENTOLA ACCIAIO INOX STAINLESS STEEL TRIVET

- Per poggiare pentole, padelle e piatti caldi appena terminata la cottura.
To place pots, pans and hot plates after cooking.
- In acciaio inossidabile.
In stainless steel.
- Pronto all'istallazione sul top grazie al biadesivo termoresistente premontato sotto ogni barretta, non è necessario forare il top.
Ready to install on the worktop thanks to the heatresistant double-sided adhesive pre-assembled under each piece, it is not necessary to drill the worktop.
- Per tutti i tipi di top purchè la superficie sia liscia..
For all types of worktops as long as the surface is smooth.
- Costituito da 1 quadrato da 66 mm. e da 4 quadrati da 30 mm.
Consisting of 1 square of 66 mm and 4 squares of 30 mm.

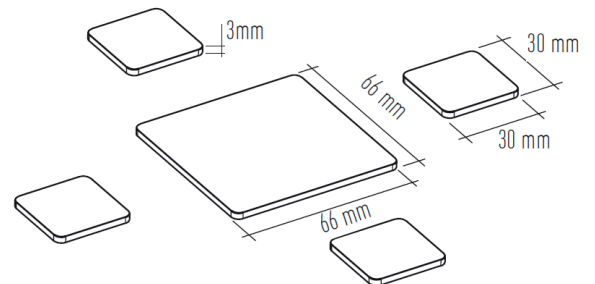

CODICE
code

acciaio satinato
satin steel

08704034X



SOTTOPENTOLA ACCIAIO INOX STAINLESS STEEL TRIVET

- Per poggiare pentole, padelle e piatti caldi appena terminata la cottura.
To place pots, pans and hot plates after cooking.
- In acciaio inossidabile.
In stainless steel.
- Pronto all'istallazione sul top grazie al biadesivo termoresistente premontato sotto ogni barretta, non è necessario forare il top.
Ready to install on the worktop thanks to the heat-resistant double-sided adhesive pre-assembled under each piece, it is not necessary to drill the worktop.
- Per tutti i tipi di top purchè la superficie sia liscia..
For all types of worktops as long as the surface is smooth.
- Costituito da un pezzo rotondo diametro 55 mm. e da 6 pezzi rotondi diametro 30 mm.
Consisting of a 55 mm diameter round piece and 6 30 mm diameter round pieces.

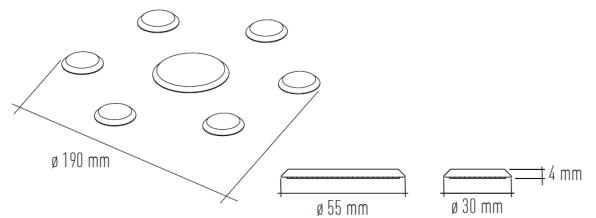

CODICE
code

acciaio satinato
satin steel
nero black

08704035X

08704035N

GANCIO MAGNETICO PER ZOCCOLO

MAGNETIC COUPLING FOR PLINTH



Sistema di aggancio tra zoccolo e piedino del mobile.
È costituito da un elemento metallico agganciato al piedino e da un elemento contenente un magnete al neodimio fissato allo zoccolo.

Questo sistema permette di agganciare e sganciare rapidamente lo zoccolo, rendendo la pulizia e la manutenzione estremamente facili.

Fixing system between plinth and leg of the furniture.

It consists of a metal clip attached to the leg and a neodymium magnetic support fixed to the plinth.

This system allow the plinth to be quickly hooked on and released, making cleaning and maintenance easily.

cod. 5706501

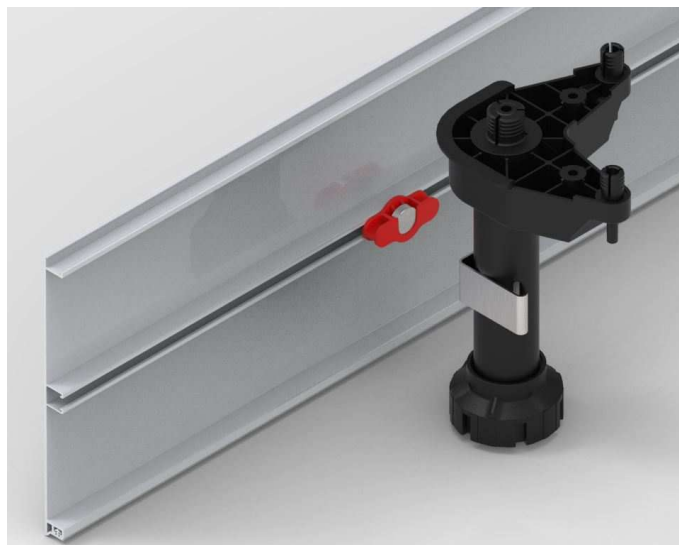

Tipo di applicazioni - Type of applications

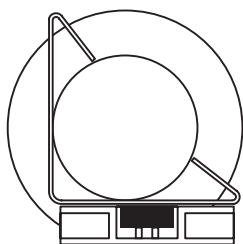

A

Lineare - Linear

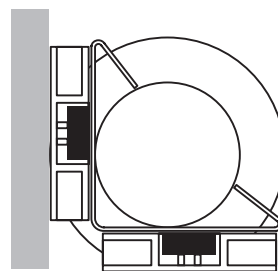

B

Angolo - Corner

ESEMPIO INSTALLAZIONE GANCI- EXAMPLE OF INSTALLING COUPLING

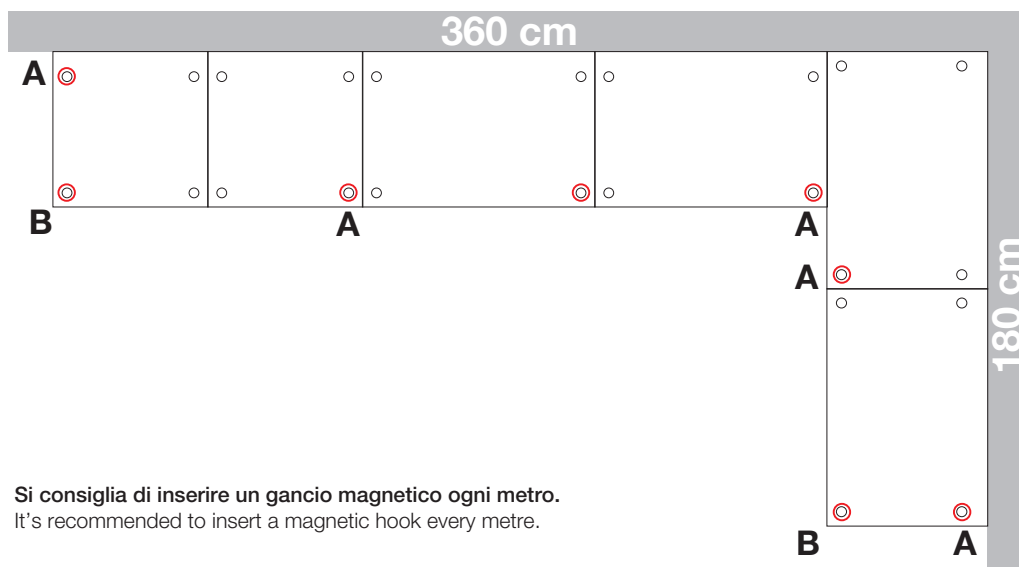

Video

Si consiglia di inserire un gancio magnetico ogni metro.
It's recommended to insert a magnetic hook every metre.

PANNELLO INOX DI PROTEZIONE RETRO PIANO COTTURA

PROTECTION STAINLESS STEEL PANEL REAR COOKER HOB



Il pannello in acciaio inox sp. 2 mm funge da protezione per lo schienale dal piano cottura a gas. Viene fissato tramite un apposito biadesivo resistente al calore.

Si raccomanda l'utilizzo su schienali in laminato.

The stainless steel panel th. 2 mm serves as protection of the back panel from the cooker hob. It is applied using a special double-sided adhesive heat-resistant.

It's recommended for use on laminate back panel.

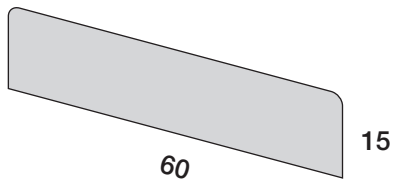

Modulo L 60

08630015

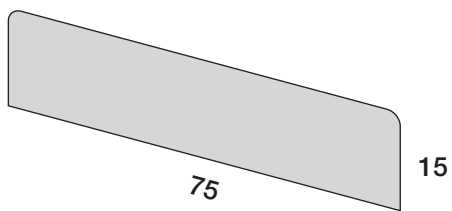

Modulo L 75

08630016

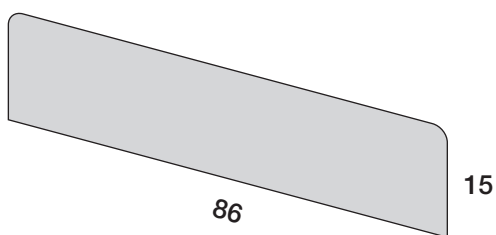

Modulo L 86

08630017

PANNELLO DI PROTEZIONE VETRO RETRO PIANO COTTURA

PROTECTION STAINLESS STEEL PANEL REAR COOKER HOB



Il pannello in vetro retro verniciato lucido sp. 4 mm funge da protezione per lo schienale dal piano cottura a gas.

Viene fissato tramite silicone neutro.

Si raccomanda l'utilizzo su schienali in laminato.

The rear painted glass panel th. 4 mm serves as protection of the back panel from the cooker hob. It is applied using the neutral silicone.

It's recommended for use on laminate back panel.

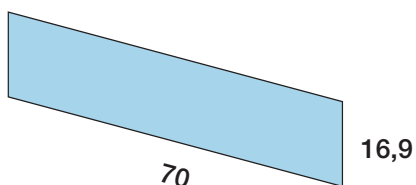

Modulo L 70

- Grigio traffico
- Lino
- Nero

08630020G

08630020L

08630020N

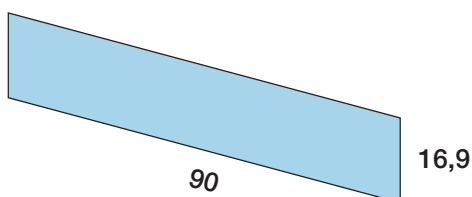

Modulo L 90

- Grigio traffico
- Lino
- Nero

08630021G

08630021L

08630021N

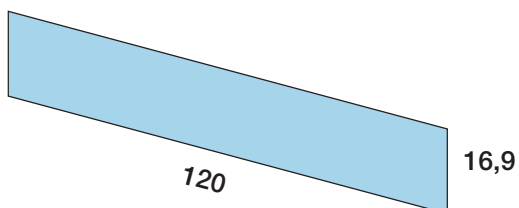

Modulo L 120

- Grigio traffico
- Lino
- Nero

08630022G

08630022L

08630022N

COLORI - COLOURS



Grigio traffico



Lino

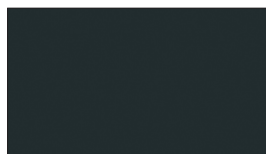

Nero

PIEDINO LIVING - Basso spessore

LIVING FOOT - Low thickness



Piedino a basso spessore in acciaio per mobili living.
Questa particolarità dà alla composizione un'estetica quasi a terra, tenendo il piedino ben nascosto.

È costituito da una piastra in metallo ed una vite di fissaggio con base d'appoggio.

Il piedino è regolabile in altezza da 7 a 10 mm.

Shallow stainless steel foot for living furniture.

This feature gives the composition an almost grounded look, keeping the foot well hidden.

Consists of a metal plate and a fixing screw with support base.
The foot is adjustable in height from 7 to 10 mm.

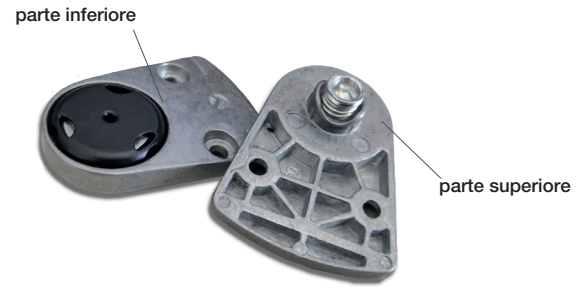

cod. 5580229

